

Compact pleated filters of type CPF

Compact pleated filters of type CPF are used for cleaning of supply and recirculation air in systems of general ventilation and air-conditioning in rooms of various purposes. These filters are generally used for II step of air cleaning (fine cleaning in accordance with EN 779) after less effective filters. Filters CPF can be used for replacement of pocket filters of type PF as they are sufficiently compact.

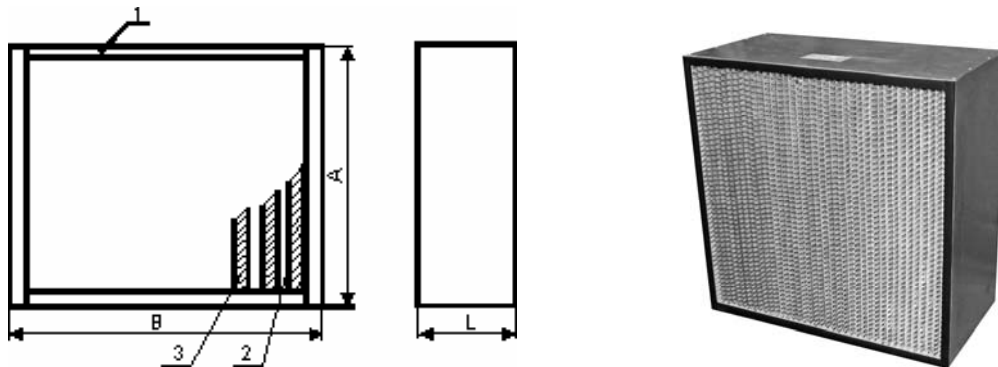

Fig. 1. Scheme of filter CPF.

CHARACTERISTICS

Table 1

Class of filter CPF by EN 779	Specific air flow, $\text{m}^3/\text{h}\cdot\text{m}^2$	Pressure drop, Pa	
		Initial	Final
F6	10000	100	450
F7	10000	120	450
F8/9	10000	140	450

The filter can be used without change of characteristics at air temperature from -40°C to $+200^{\circ}\text{C}$. Filters operating at higher temperatures of cleaned air can be manufactured by request.

GENERAL DESIGN

The filter consists of body 1 (galvanized steel) inside which filter medium is putting in pleats. To prevent connection of pleats of filter medium they are interlaid with gaffers from aluminium foil 3. The filtering package including medium with interlaid separators is sealed in the body by lining with special material or sealing on entire perimeter with special sealant.

At cleaning of large volume air these filters can be placed in filtering chamber of pleated filters of type FCCF (look the catalogue of company "NPP "Folter").

BASIC DIMENSION-TYPES

Table 2

Index of filter CPF	Dimensions, mm			Nominal air flow, m ³ /h
	Height A	Width B	Depth L	
(* 20)	500	500	292	2500
(* 22)	592	592	292	3500
(* 21)	592	287	292	1750
(* 26)	610	610	292	3700
(* 25)	610	305	292	1850
Other dimension-types of filters are manufactured by request				

* - digit, denoting filter class by EN 779.

MAINTENANCE

When filters are in operation it is necessary to check their pressure drop by reading of micromanometer attached to connecting pipes, arranged in walls of air cleaning chambers before and after filters.

Upon reaching pressure difference specified in the project, or based on available pressure in ventilating system, it is necessary to replace filters.